

FEATURES

- Compact design
- Migrated pressure chambers
- Static pressure up to 200 bar

APPLICATIONS

- Filtration plants
- Water applications
- Duct & room pressure
- Pumps & Compressors
- Clean room applications

Piston Operated



STANDARD PARAMETERS

Accuracy	: 2.5%
Ambient temperature	: -20...+65°C
Service temperature	: 100°C max
Pressure limits	: Steady pressure and over pressure up to FS value from LO to HI side
Static pressure	: 100 bar (Optional: 800 bar)

MATERIAL OF CONSTRUCTION

Sensing element	: Piston
Case	: Aluminum die casting - Black
Welded parts	: AISI 316 SS, Teflon, Ceramic Magnet & SS spring
Dial	: Aluminum, black graduation on white background
Pointer	: Fix, aluminum, black powder coated
Window	: Polycarbonate (fitted incase)

STANDARD SPECIFICATIONS

Dial size	: DN63 / DN80 / DN100 / DN160
Range	: 0...400 mbar to 0...10 bar
Mounting pattern / porting	: Direct, In-line connection
Process connection	: 1/4" NPT (F) x 2 Nos
Ingress protection	: IP 54
Execution	: Dry

WORKING PRINCIPLE

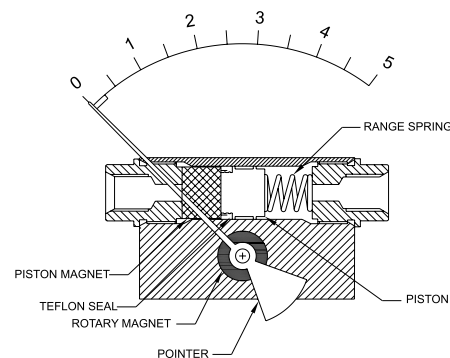

Type I

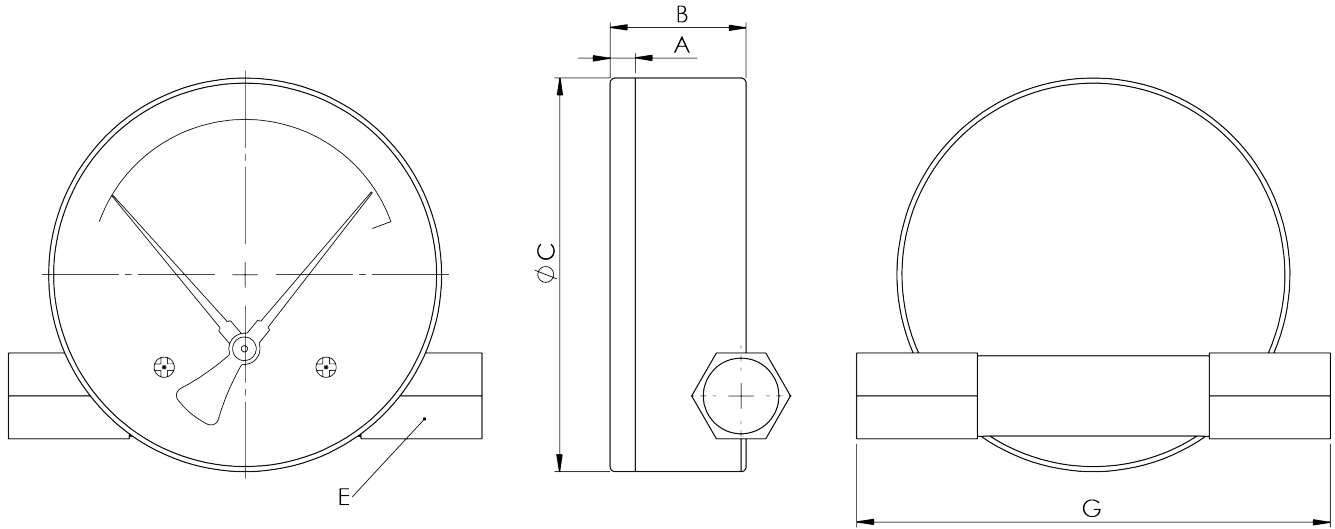

DN	A	B	C	E	G
80	4	22	78	SW17	94

Type I

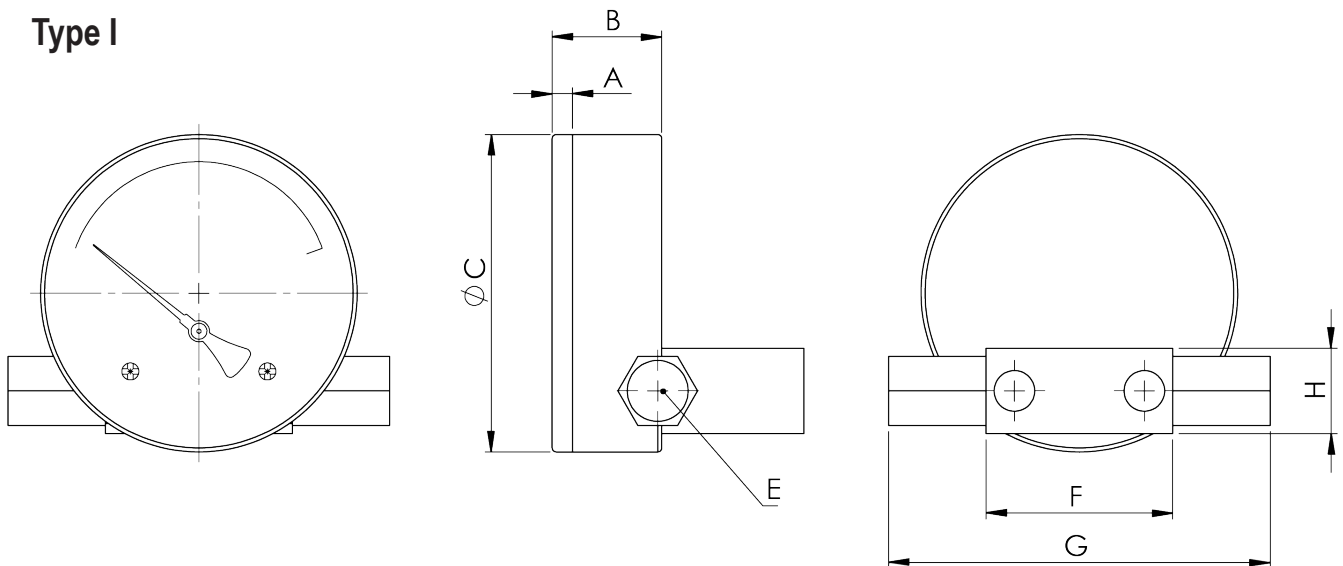

DN	A	B	C	E	G	F	H
100	14	15	156	SW22	125	86	25
160	14	27	157	SW22	111	86	25

ORDERING CODES**1. DIAL SIZE**

03	63 mm / 2½"	
04	80 mm / 3"	04
05	100 mm / 4"	
07	160 mm / 6"	

2. RANGE

XXX	Refer "Range Table"	XXX
------------	---------------------	------------

3. MOUNTING PATTERN / PORTING

A	Direct Bottom connection	
I	In-line connection	I
J	Centre, Back connection	

4. PROCESS CONNECTION

02B	¼" BSP (F) X 2 Nos.	
02N	¼" NPT (F) X 2 Nos.	02N
Other thread size and standards available on request		

5. INGRESS PROTECTION

EV	IP 54	EV
-----------	-------	-----------

6. EXECUTION

EA	Dry	EA
EG	Dampening liquid filled, glycerine	
EH	Dampening liquid filled, silicon oil ²	

7. OTHER OPTIONS

TB	Calibration certificate	TB
XG	SS tag plate, AISI 316 SS	
XF	SS tag plate, AISI 304 SS	
XR	Custom designed dial	
XT	Dial tag marking	
GW	Maximum Reading pointer	
B7	With 3-Hole front panel	
250	Static pressure : 200 bar	

Ordering Example : PG13-DPG-04-XXX-I-02N-EV-EA-TB

NOTES

For other connections, please contact factory.

STANDARD RANGES

RANGE	"bar"	"kg/cm ² "	"bar / psi"	RANGE	"psi"	RANGE	"kPa"	RANGE	"MPa"
0...0.6	B01	K01	N01	0...10	S01	0...60	E01	-	-
0...1	B02	K02	N02	0...15	S02	0...100	E02	0...0.1	M02
0...1.6	B03	K03	N03	0...25	S03	0...160	E03	0...0.16	M0.3
0...2.5	B05	K05	N05	0...35	S05	0...250	E05	0...0.25	M05
0...4	B06	K06	N06	0...90	S07	0...600	E07	0...0.6	M07
0...6	B07	K07	N07	0...150	S09	0...1000	E09	0...1	M09
0...10	B09	K09	N09	0...235	S11	0...1600	E11	0...1.6	M11
0...16	B11	K11	N11	0...365	S13	0...2500	E13	0...2.5	M13
0...25	B13	K13	N13	0...600	S16	0...4000	E14	0...4	M16
0...40	B16	K16	N16	0...800	S17	0...5000	E15	0...6	M17
0...60	B17	K17	N17	0...1000	S18	0...6000	E17	0...7	M18
0...70	B18	K18	N18	0...1500	S19	0...7000	E18	0...10	M19
0...100	B19	K19	N19	0...2300	S21	0...10000	E19	0...16	M21
0...160	B21	K21	N21	0...3600	S24	0...16000	E21	0...25	M24
0...250	B24	K24	N24	0...6000	S27	0...25000	E24	0...40	M27
0...400	B27	K27	N27	0...8700	S29	0...40000	E27	0...60	M29
0...600	B29	K29	N29	0...10000	S30	0...60000	E29	0...70	M30
0...700	B30	K30	N30	0...15000	S31	0...70000	E30	0...100	M31
0...1000	B31	K31	N31	0...23200	S34	-	-	0...160	M34
0...1600	B34	K34	N34	-	-	-	-	0.1...0	M37
-1...0	B37	K37	N37	-	-	-100...0	E37	-0.1...0.06	M38
-1...0.6	B38	K38	N38	-	-	-100...60	E38	-0.1...0.15	M39
-1...1.5	B39	K39	N39	-	-	-100...150	E39	-0.1...0.3	M42
-1...3	B42	K42	N42	-	-	-100...300	E42	-0.1...0.5	M43
-1...5	B43	K43	N43	-	-	-100...500	E43	-0.1...0.9	M45
-1...9	B45	K45	N45	-	-	-100...900	E45	-0.1...1.5	M47
-1...15	B47	K47	N47	-	-	-100...1500	E47	-0.1...2.4	M49
-1...24	B49	K49	N49	-	-	-100...2400	E49	-	-

NOTES

- Other scales & measurement units are available.
- Equivalent scales available in kg/cm², psi, kPa, MPa, bar/psi, kPa/bar, kPa/psi or any other special scales.
- Primary scales shall be in "BLACK" and secondary scales shall be "RED".
- Special scales, custom dial design, OEM/private logo printing is available, details contact our marketing team.